

URINAL JOINING ASSEMBLIES

If access into a building is restricted or if lengths longer than four metres are required, urinals can be made in sections for assembly on site using a joint cover trim for straight joints or a corner capping for corner joints.

Each section is manufactured as a separate urinal with its own waste fitting and cistern, and the only tool required is the 3mm Allen Key supplied.

Using this system urinals of any size and shape can be manufactured and delivered in easy to handle sections.

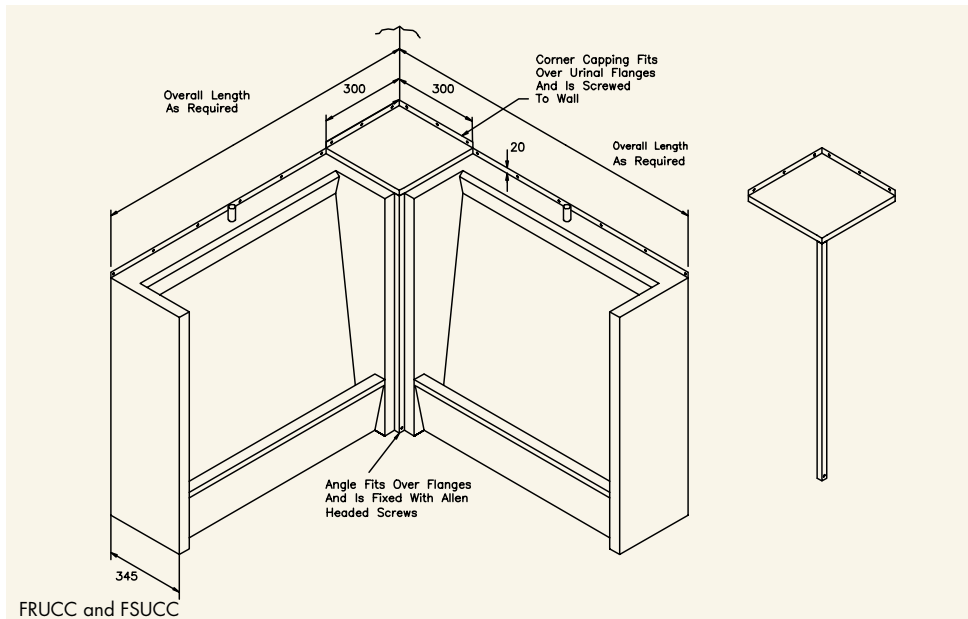
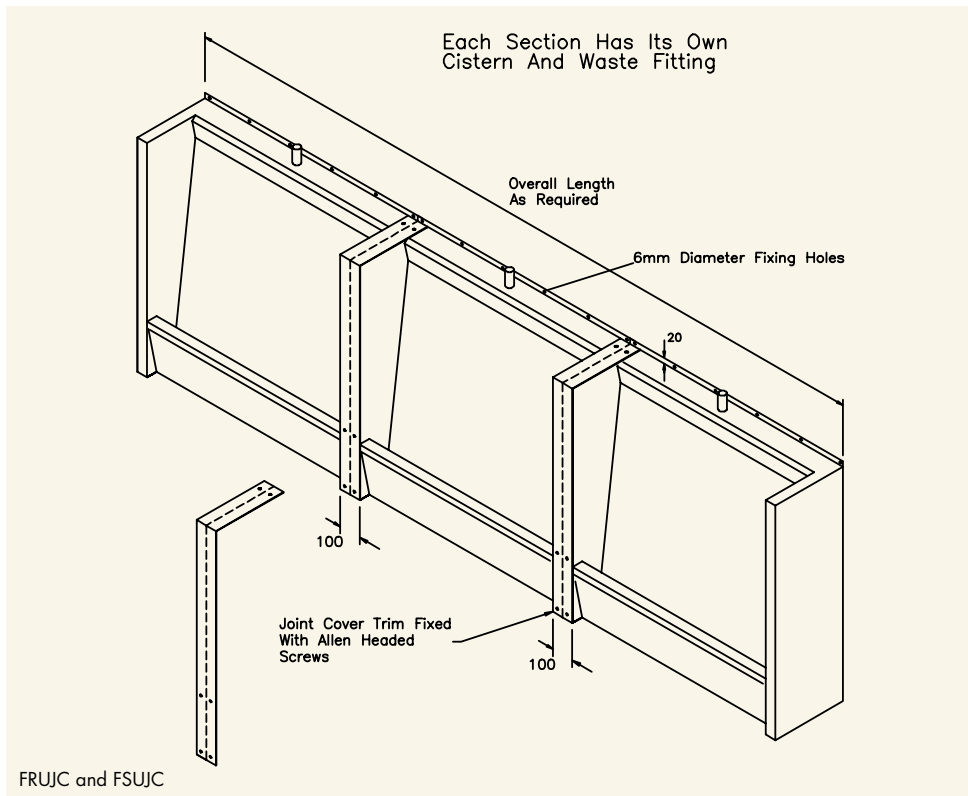

- 1 FRUJCT Joint cover trim for floor recessed urinal
- 2 FRUCC Corner capping for floor standing urinal
- 3 WHJCT Joint cover trim for wall hung urinal
- 4 WHCC Corner capping for wall hung urinal

PRODUCT DESCRIPTION	ORDERING CODE
Joint Cover Trim for Floor Recessed Urinal	FRUJCT
Corner Capping for Floor Recessed Urinal	FRUCC
Joint Cover Trim for Floor Standing Urinal	FSUJCT
Corner Capping for Floor Standing Urinal	FSUCC
Joint Cover Trim for Wall Hung Urinal	WHJCT
Corner Capping for Wall Hung Urinal	WHCC

urinals