

## CLEANERS SINK

A 304 grade stainless steel cleaner's sink designed for heavy duty use, supplied with stainless steel hinged bucket grating, front support legs and a 38mm (1 1/2" BSP) waste/overflow fitting.

## CLEANERS COMBINATION UNIT

A 304 grade stainless steel Cleaners combination unit providing both hand wash and bucket filling facilities. The unit is supplied with a stainless steel hinged grating, a swivel tap, a 32mm (1 1/4" BSP) waste/overflow fitting to the basin and a 38mm (1 1/2" BSP) waste/overflow fitting to the bucket sink.

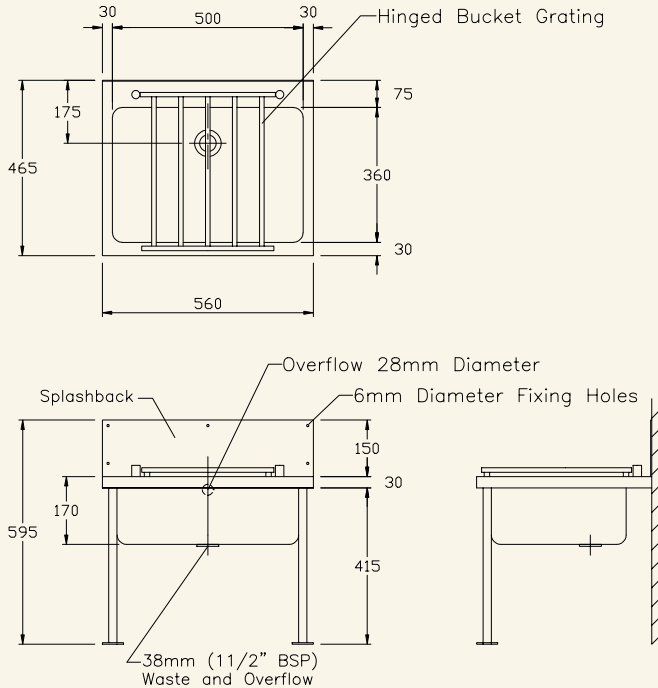

CS

1 Cleaner's Sink

2 Cleaner's Combination Unit

3 Bucket Grating

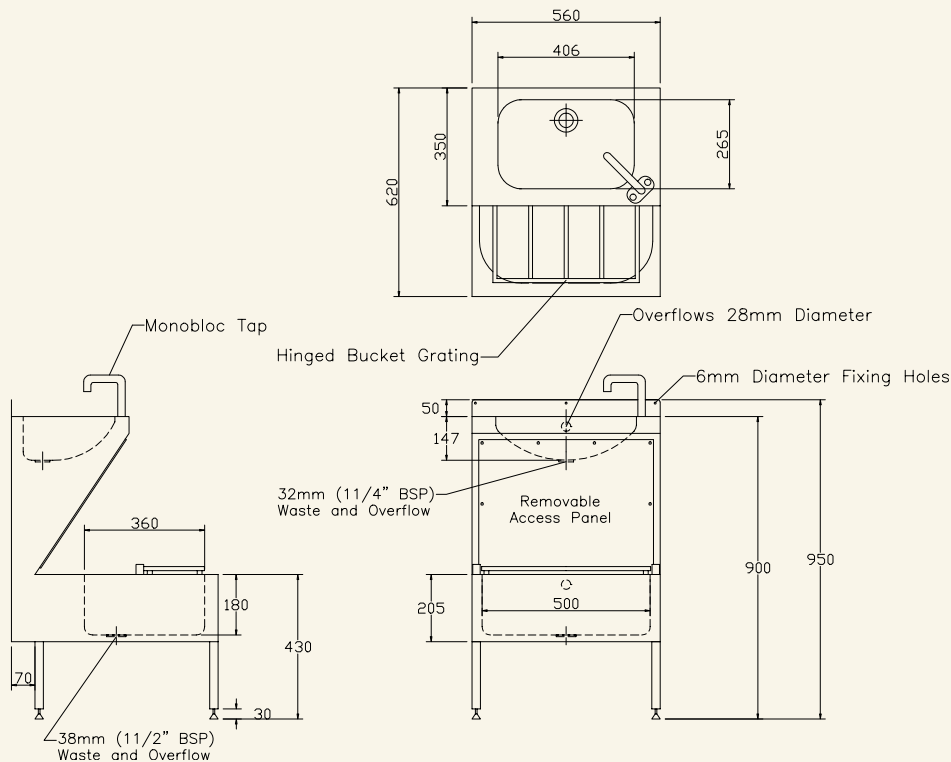

CCU

### PRODUCT DESCRIPTION

Cleaner's Sink  
Cleaner's Combination Unit

### ORDERING CODE

CS  
CCU